

BMW R1200C Classic - Montauk 1997-2004

PIECES INCLUSES	PARTS INCLUDED
1 Attache	1 Hitch
1 Boule 1-7/8"	1 Ball 1-7/8"
1 Plaque de chaîne de sécurité	1 Safety chain plate
2 Tige aluminium 5" cc (2 boulons 5/16x3/4", 2 rondelles frein, 2 capuchons chrome 5/16)	2 Aluminium holders 5" cc (2 bolts 5/16x3/4", 2 lock washers, 2 cap nut 5/16)
2 Boulons 1/4 x 1"	2 Bolts 1/4 x 1"
2 Rondelle freins	2 Lock washers

- 1- L'attache se boulonne au support des pédales arrière.
- 2- Les bras d'aluminium se fixent à l'écrou M8 sous l'aile arrière.

- 1- Hitch bolts on rear foot-pegs bracket.
- 2- Holders bolt on M8 nuts on rear fender, behind license plate frame.

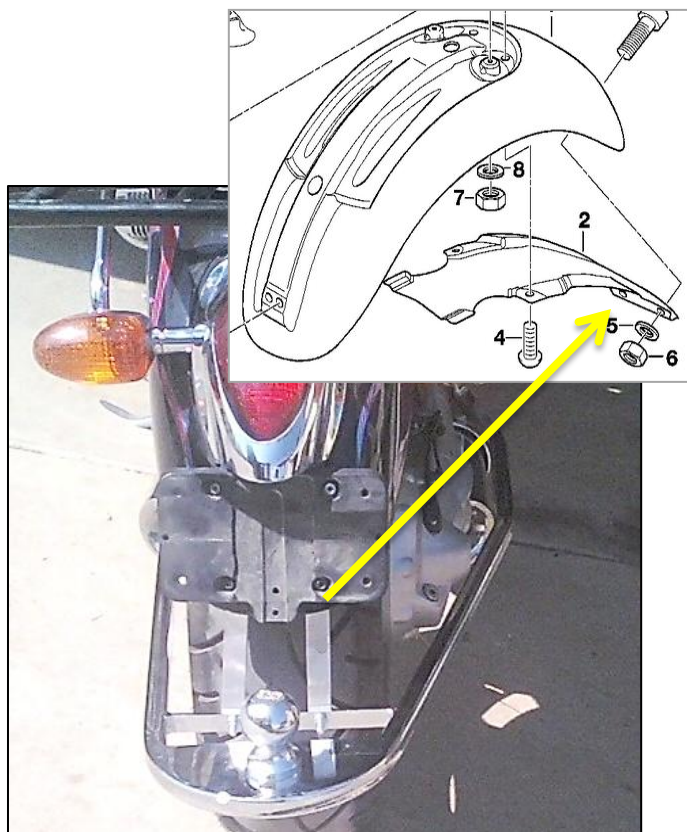
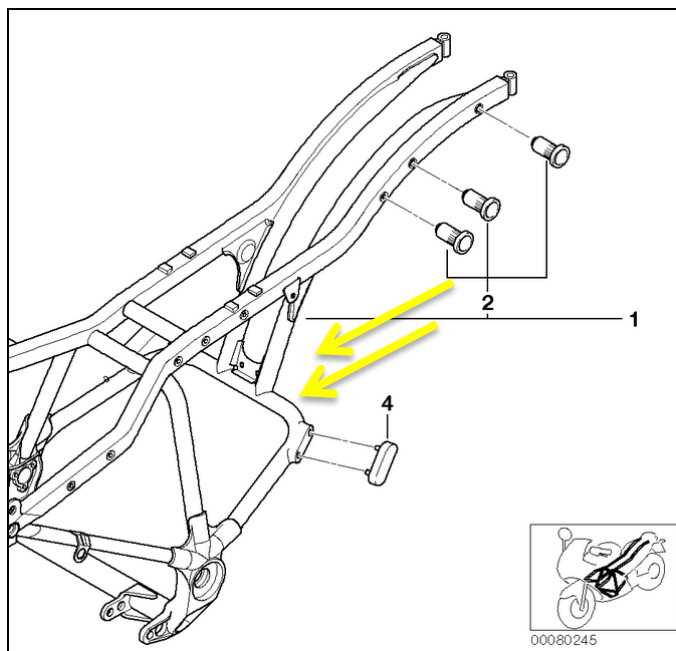

**ATTENTION !** L'installateur a la responsabilité de s'assurer que tout, y compris les composantes préassemblées, soit bien serré avant d'utiliser la moto.

*It is the installer's responsibility to ensure that all of the fasteners (including preassembled) are tightened before operation of the motorcycle.*